

Fun/STEM/HE

Activity

Ten

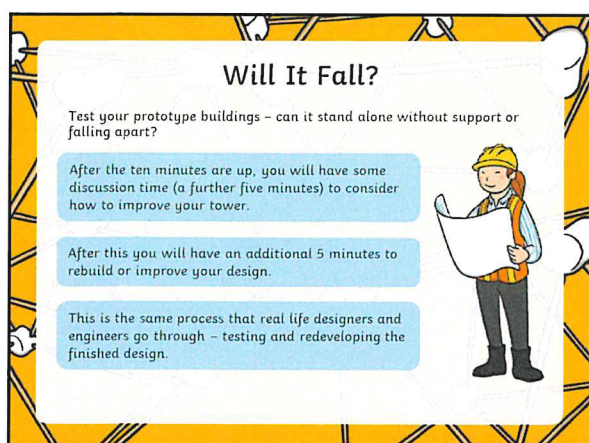

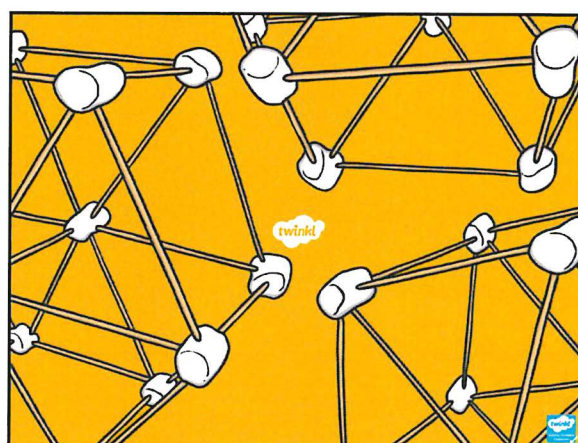
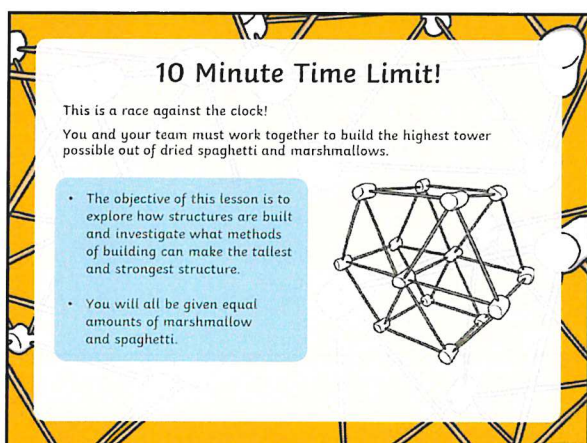
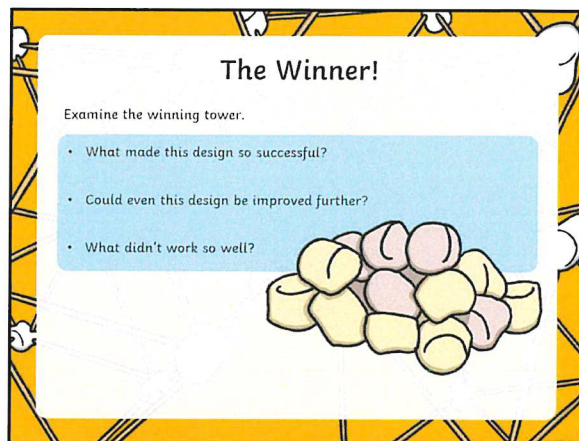
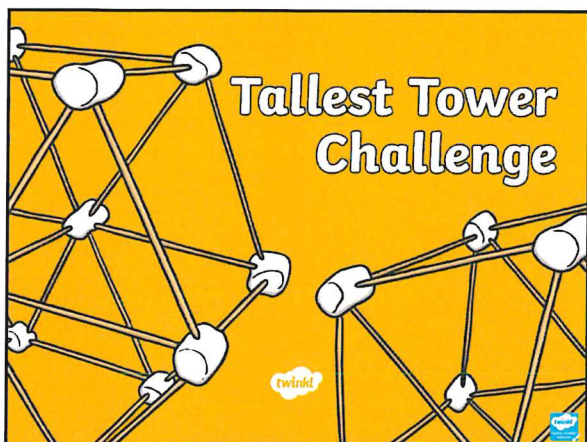

Personal Transport of the Future

Name:

Class/School:

Self-Portrait:

Situation:

As electric powered vehicle technology becomes more and more affordable and compact, young people aged between 12 and 18 will become a target market for new and innovative personal transport designs.

Design Brief:

I am going to design a...

Investigation Statement:

The main reasons people need personal transport is...

Design Partner:

My design partner for this project is: _____

Product Analysis

Label the parts of the product. What materials are they made from?

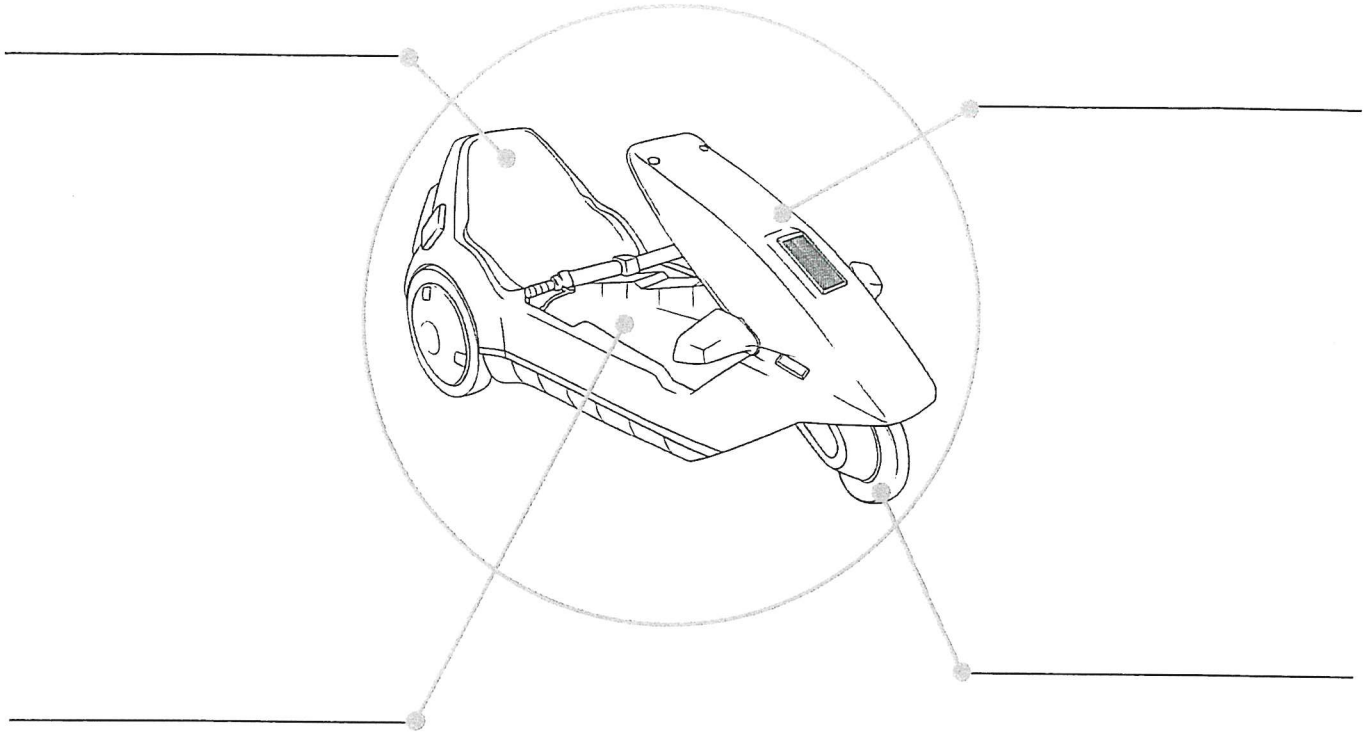

Why the Sinclair C5 was a good idea:

Why the Sinclair C5 was a bad idea:

Specification

To be successful, my personal transport needs to be:

1. _____
2. _____
3. _____

Design Ideas

Use sketches and notes to show your ideas.

Blank area for drawing and notes.

Design Partner Comment

I like _____

I would change _____

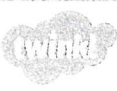

Development of Chosen Idea

Draw your chosen idea into a finished design. Add as much detail as you can either by drawing or by annotation.

Design Partner Comment

I like this finished idea because:

Evaluation

I like my final design because:

Reflection on Specification

To be successful, my product needed to be:

1. _____
2. _____
3. _____

Reflection on Specification

How my design meets those points:

1. _____
2. _____
3. _____

Back to the Beginning

If I were to start this again, I would make the following changes:

1. _____
2. _____
3. _____

Special Baked Beans

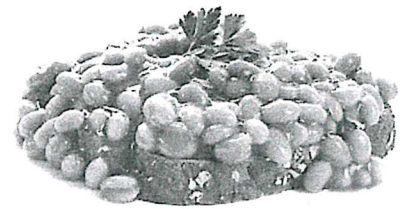

Ingredients:

$\frac{1}{2}$ tin baked beans
 $\frac{1}{2}$ onion
2 slices of bacon
25g butter
 $\frac{1}{2}$ teaspoon brown sugar
 $\frac{1}{2}$ teaspoon vinegar
Worcester sauce
2 slices wholemeal bread

Equipment:

Saucepan
red/brown chopping boards
kitchen scissors
vegetable knife
teaspoon
knife
2 large plates
2 small plates
Wooden spatula

Method:

1. Collect equipment and ingredients.
2. Cut bacon with scissors.
3. Peel and finely chop onion.
4. Heat oil in saucepan over a low heat.
5. Gently fry bacon and onion for 5 minutes.
6. Put bread in toaster.
7. Add beans to bacon and onion and mix.
8. Add sugar and vinegar and a few drops of Worcester sauce.
Heat thoroughly.
9. Spread remaining butter on toast and serve beans on top.

Toasted Sandwiches



Ingredients:

2 slices of bread
Butter
Fillings:
Tuna and onion
Mayonnaise
Cheese
Ham

Equipment:

toasted sandwich maker
white chopping board
knife
vegetable knife
2 plates
Grater
Small white bowl
Plate
Fork

Method:

1. Collect ingredients and equipment.
2. Switch on toastie machine.
3. Spread one side of each slice of bread with butter.
4. Chop onion.
5. Mix with tuna and mayonnaise.
6. Place filling on side of bread not buttered.
7. Place other slice of bread on top, buttered side up.
8. Place on toasted sandwich maker and cook until toasted sandwich is golden brown and filling is cooked.

Other fillings:-

Ham and cheese	-	chop ham, grate cheese.
Ham, cheese and tomato	-	chop ham and tomato. Grate cheese.
Cheese and pineapple	-	Grate cheese, cut pineapple into small pieces.